

# ROLLER'S *pressing tools*

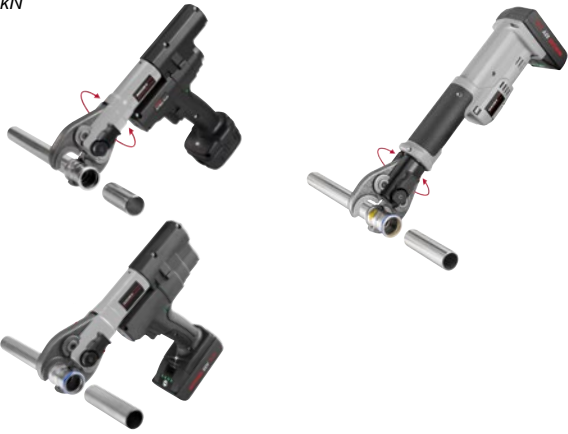

22 kN



32 kN



XL 32 kN / XL 45 kN



*German Top Quality*

## **ROLLER'S universal radial presses for pressfitting systems!**

ROLLER'S radial presses can be used universally for all common pressfitting systems and satisfy all the criteria regarding work safety, functional safety and operating safety for perfect, system-conformant safe pressing.

ROLLER produces

- Manual radial presses with locking end stop,
- Hybrid radial presses 22 kN (for cordless and mains operation) with automatic circuit control,
- Electric radial press 32 kN with automatic circuit control,
- Hybrid radial press 32 kN (for cordless and mains operation) with automatic circuit control,
- Electric radial press XL 32 kN with automatic circuit control,
- Hybrid radial press XL 45 kN (for cordless and mains operation) with automatic circuit control.

ROLLER offers the right solution for every application.

Extensive endurance tests and the comprehensive ROLLER quality assurance system confirms the high reliability and the high quality of the ROLLER'S pressing tools as well as the constant shear force of the ROLLER'S radial presses for constantly reliable pressing.

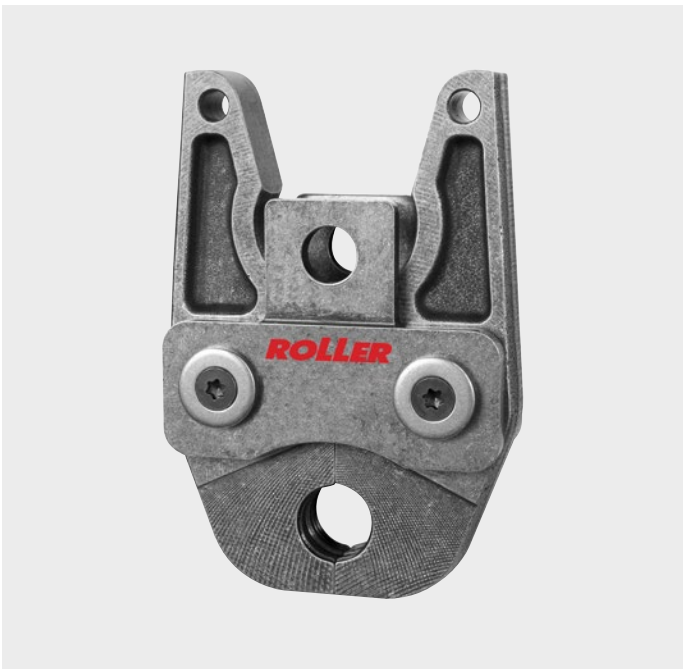
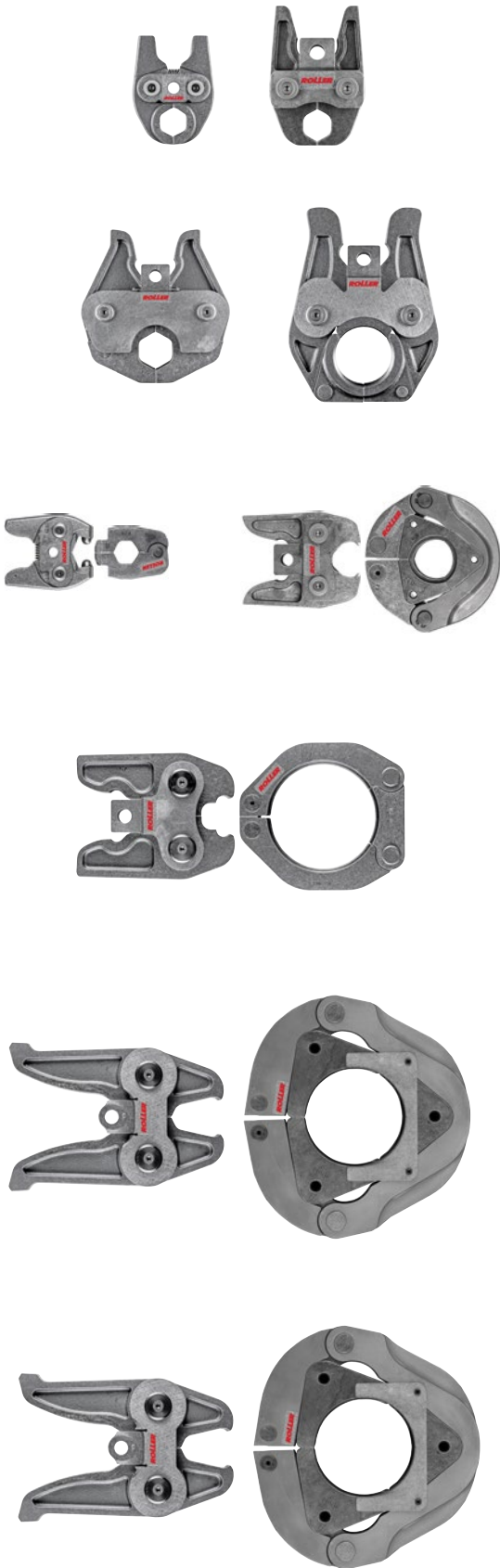

**ROLLER'S pressing tongs / pressing rings / pressing rings XL for maximum quality requirements!**

*ROLLER'S Mini pressing tongs/ROLLER'S pressing tongs/ROLLER'S pressing rings with adapter tongs/ROLLER'S XL pressing rings with XL adapter tongs are made from drop-forged and tenacious, specially hardened special steel and can therefore safely withstand the necessary pressing forces.*

*The respective system-specific pressing contour is formed with high precision in one action, together with the identification of the pressing contour and size, and exactly rounded on CNC machining centres. This ensures perfectly system-conformant, reliable pressing and long life.*

*ROLLER'S Mini pressing tongs/Mini adapter tongs with ROLLER'S pressing rings S: Driven by all ROLLER'S 22 kN radial presses.*

*ROLLER'S pressing tongs/adapter tongs with ROLLER'S pressing rings: Driven by all ROLLER'S 32 kN radial presses and by suitable drive units of other makes with 32 kN thrust.*

*Z6 XL adapter tongs with ROLLER'S XL pressing rings: Driven by ROLLER'S Uni-Press XL ACC.*

*Z6 XL 45 kN adapter tongs with ROLLER'S XL pressing rings: Driven by ROLLER'S Multi-Press XL 45kN 22 V ACC.*



German Top Quality