

# ROLLER'S Uni-Press XL ACC

Two connections for ROLLER'S manual radial press and ROLLER'S 32 kN radial presses

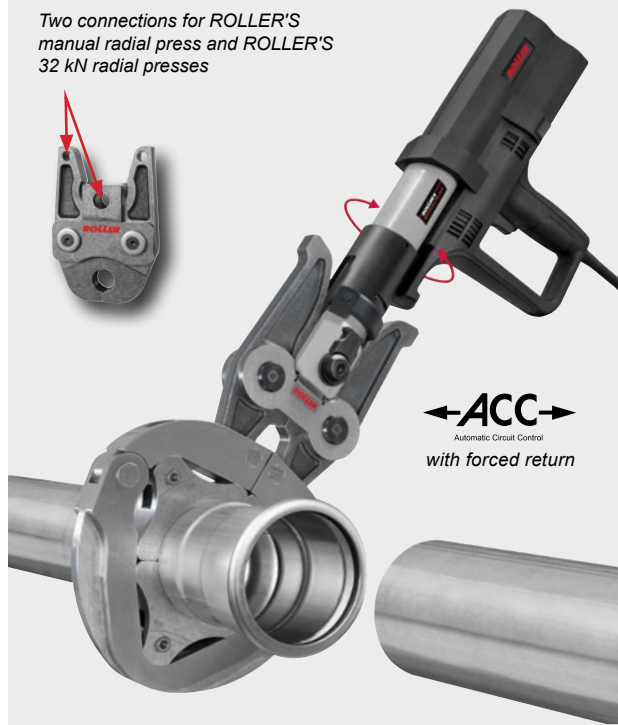

**←ACC→**  
Automatic Circuit Control  
with forced return

German Top Quality



**Powerful, robust, compact electric radial press XL 32 kN with automatic return (forced return). For radial pressing joints Ø 10–108 (110) mm, Ø ¼–4".**

- For fast, safe pressing of Ø 10–110 mm in just one action. Ultra-fast, e.g. Geberit Mapress Stainless-steel Ø 108 mm in only 15 s.
- Universal for all ROLLER'S pressing tongs (except ROLLER'S Mini pressing tongs), ROLLER'S pressing rings and ROLLER'S pressing ring XL, as well as for other suitable makes of pressing tongs / pressing rings.
- Compact design, slim form, comfortable weight, drive unit only 5.5 kg.
- Ergonomically designed housing with soft grip and recessed grip.
- Rotatable pressing tongs by housing on rotary bearing.
- Pressing process with ACC – for work safety and operating safety. Automatic return (forced return) after completed pressing.
- Several tons feed and pressing force for perfect, split-second pressing. Thrust 32 kN. Robust, powerful, electrohydraulic drive with eccentric piston pump with robust planetary gear and compact high-performance hydraulic system. Long working stroke for pressings in just one action, ideal for large dimensions.
- Proven, powerful 1~ universal motor 230 V, 50–60 Hz, 450 W, with safety switch.
- Constant shear force for constantly reliable pressing.
- Secure seating of pressing tongs/adaptor tongs by automatic locking. Adjustable protective guard.
- **Complete range of ROLLER'S pressing tongs / pressing rings / pressings XL for all common pressfitting systems, see page 100–140.**  
With precisely worked and exactly rounded, system-specific press contour according to the respective pressfitting system. For perfect system-conformant, reliable pressing.  
The pressing tongs / pressing rings / pressing rings XL are made from tenacious, specially hardened special steel and they are therefore highly resistant. For maximum quality demands and long life.  
ROLLER'S pressing tongs/pressing rings fit all ROLLER'S 32 kN radial presses and suitable drive units of other makes with 32 kN thrust.  
All pressing tongs marked by a \* have an additional connection for manual driving by the ROLLER'S Easy-Press drive unit.  
All pressing rings S (PR-2B) marked with \*\* can also be driven with the manual radial press ROLLER'S Easy-Press using the adapter tong Z8, see page 140.
- Confirmations of suitability see page 52.
- Liability acceptance agreements see page 53.

Scope of Delivery

Art.-No.

€

### ROLLER'S Uni-Press XL ACC Basic-Pack

32 kN drive unit with forced return, in XL-Boxx system case

579012 A220

**2.344,84**

#### Accessories

**ROLLER'S pressing tongs / pressing rings / pressing rings XL**

See page 100–140

**Z6 XL adapter tongs for driving the ROLLER'S pressing rings 64.0 – 108.0 XL (PR-3S), 2 ½–4" XL (PR-3S) with ROLLER'S Uni-Press XL ACC**

579120 R

373,68

**Adapter tongs for other ROLLER'S pressing rings**

See page 140

**ROLLER'S Uni-Press XL ACC drive unit with forced return**

579000 A220

2.096,76

**ROLLER'S cropping tongs M for threaded bars**

See page 142

**ROLLER'S cable shears for electric cables**

See page 142

**XL-Boxx system case with inlay**

579601 A

248,08

